

A close-up photograph of two silver-colored metal door operator components. The top component is a long, rectangular housing with a small DORMA logo embossed on its top surface. Below it is a shorter, narrower component. A semi-transparent white box is overlaid on the left side of the image, containing the text "ED 100LE" and "ED 250LE" with a horizontal line below the second line. The background is a plain, light gray surface.

ED 100LE  
ED 250LE  
—

Low energy swing  
door operators

## LOW ENERGY SWING DOOR OPERATORS

Automatic doors provide a means of opening and closing doors without the need for physical effort. For many people who lack physical ability or who are encumbered, by for example shopping or push chairs, heavy manual doors can be a barrier to access. With the ED 100LE / ED 250LE, DORMA has developed a Low Energy swing door operator designed to remove this barrier and provide easy and safe access for all users.

The unit offers a range of operating modes which enable the door to be opened under power when required and used as a conventional manual swing door at all other times.

The ED 100LE / ED 250LE opens the door at precisely controlled speeds and forces assuring safety for all users. In the majority of applications, the ED 100LE / ED 250LE does not require additional safety equipment. It is not only extremely safe but is less expensive than traditional automatic swing door operators. The combination of low operating noise levels and the compact Contur design ensures the ED 100LE / ED 250LE will integrate into the most sensitive of environments.

With our ED 100LE / ED 250LE, DORMA offers electro-mechanical low energy swing door operators for various fields of application. Simply select the suitable version according to your door-leaf width and weight: While the ED 100LE is suitable for doors with a weight of up to 100 kg and a door width of up to 1,100 mm, the ED 250LE is designed for doors with a width of up to 1,600 mm and a door weight of up to 250 kg. Both operators may be installed as push-version with standard arm or as pull-version with slide channel.



### Benefits

- Elegant visual appearance: DORMA Contur design provides an operator height of only 70mm.
- Low noise levels through multi-stage gearing.
- Efficient closing due to an electronic latching action enabling the motor to support the spring to overcome door seals, room to room pressure differentials and wind loads.
- Suitable for 60 minute fire rated doors for both push and pull application.
- Optional additional safety: Compatible with IRS safety sensors where applications are for particularly vulnerable users.
- Optional integrated door co-ordinator to ensure the correct closing of rebated double doors.

### DORMA and the Environment

DORMA takes its responsibilities seriously to minimise impact on the environment in all aspects of its activities. This philosophy has remained a key driver throughout the development of the ED 100LE / ED 250LE.

- We have attached particular importance to using as little material as possible, and have managed to reduce by almost 40% the required material compared to our previous generation of low energy door operators. The low weight has a positive effect on the shipping of the goods and thus reduces unnecessary CO<sub>2</sub> emissions.
- Even the best operator will require replacement one day; we are prepared for this as all components are recyclable.
- The ED 100LE / ED 250LE along with all DORMA swing door operators provides sufficient force reserves. Even when the system is used to the maximum the operator will always try to open and close the door perfectly within the statutory limits. DORMA swing door operators contribute to avoiding the loss of heat thereby contributing towards reducing a building's carbon footprint.
- Where required, IRS safety sensors consume significant amounts of power over a 24 hour period when mains power is not turned off – as is the case in the vast majority of buildings. The ED 100LE / ED 250LE offers an integrated ESM Energy Saving Mode function which allows the sensors to be switched to standby to minimise unnecessary power consumption which offers an energy saving of up to 30%.
- The ED 100LE / ED 250LE mainly closes via spring force. However, thanks to its direct drive, the motor automatically switches on to provide support when required. This assists the door to reach its closed position minimising energy loss.

**Required operating conditions**

Ambient temperature	-15 to +50 °C
Only suitable for dry environments	Relative humidity max. 93 % Non-condensing
Power supply	230 V AC 50 Hz +/- 10 %
Class of protection	IP20

**General specifications**

Dimensions (W x H x D)	685 x 70 x 130 mm
Min. clearance between hinges (double-leaf systems)	1,450 mm
Min. clearance between hinges for ESR (double-leaf systems)	1,450 mm
Weight of single-leaf version	12 kg
Power supply for external accessories	24 V DC +/- 10 %, 1.5 A

**Parameters**

Opening angle	Max. 110°
Latching action	Adjustable from 7° – 0°
Hold-open time	0 – 30 seconds
First entry-last exit hold-open time	0 – 30 seconds
Blocking behaviour	Reversing closing cycle/ Door closer function
Locking feedback contact	Motor lock/Electric strike
Working point of wind load control	Total load of max. 50 Nm
Voltage-independent braking circuit	Adjustable via potentiometer
Electronic latching action pulse	Force adjustable

**Integrated functions**

LED status indicator	green	24V DC voltage indicator
	red	Error Code
	yellow	Service interval expired
Integrated program switch	OFF	
	AUTOMATIC	
	PERMANENT OPEN	
	EXIT ONLY (OPTIONAL – only for single-leaf systems)	
User interface with information display	Status indicator and parameterisation	
Slot for DORMA Upgrade Cards	Extension of functional range	
Update interface	Firmware update	
TMP – Temperature Management Program	Temperature-related overload protection	
IDC – Initial Drive Control	Driving phase optimisation	
Cycle counter	0 – 1,000,000 (reasonably subdivided)	

**Inputs, terminals max. 1.5 mm<sup>2</sup>**

Potential-free activator	Inside and outside
Voltage input/First entry-last exit	Max. 8 – 24 V AC/DC + 10%
First entry-last exit (key switch)	NC contact/NO contact
Safety sensor	Hinge side and opposite hinge side
Test signal for safety sensor	Hinge side and opposite hinge side
Emergency-Off pushbutton/Lock switch	NC contact/NO contact

**Outputs, terminals max. 1.5 mm<sup>2</sup>**

Potential-free door status contact	Door closed
	Door open

**ED 100LE**

Power consumption	120 Watts
Closing force EN 1154	EN 2–4, adjustable
Max. door-leaf weight for lintel depths of up to 300 mm	100 kg
Door-leaf width for single-leaf version	700 – 1,100 mm hinged 770– 1,100 mm pivoted*
Door-leaf width for double-leaf version	1,450 – 2,200 mm hinged 1,590– 2,200 mm pivoted*
Max. opening speed	27° per second
Max. closing speed	27° per second
Axle extension	30 mm / 60 mm
Lintel depth for slide channel	+/- 30 mm
Lintel depth for standard arm	0 – 300 mm

\* Based on 70 mm pivot centres.

**ED 250LE**

Power consumption	240 Watts
Closing force EN 1154	EN 4–6, adjustable
Max. door-leaf weight for lintel depths of up to 225 mm	250 kg
Max. door-leaf weight for lintel depths from 226 mm to 500 mm	120 kg
Door-leaf width for single-leaf version for single-leaf fire protection doors	700 – 1,600 mm hinged 770– 1,600 mm pivoted* 700-1,400 mm
Door-leaf width for double-leaf version for double-leaf fire protection doors	1,450 – 3,200 mm hinged 1,590– 3,200 mm pivoted* 1,400-2,800 mm
Max. opening speed	27° per second
Max. closing speed	27° per second
Axle extension	30 mm / 60 mm / 90 mm
Lintel depth for slide channel	+/- 30 mm
Lintel depth for standard arm	0 – 500 mm

\* Based on 70 mm pivot centres.

View: BASIC cover, pull-version, 12.5 mm drive arm pin

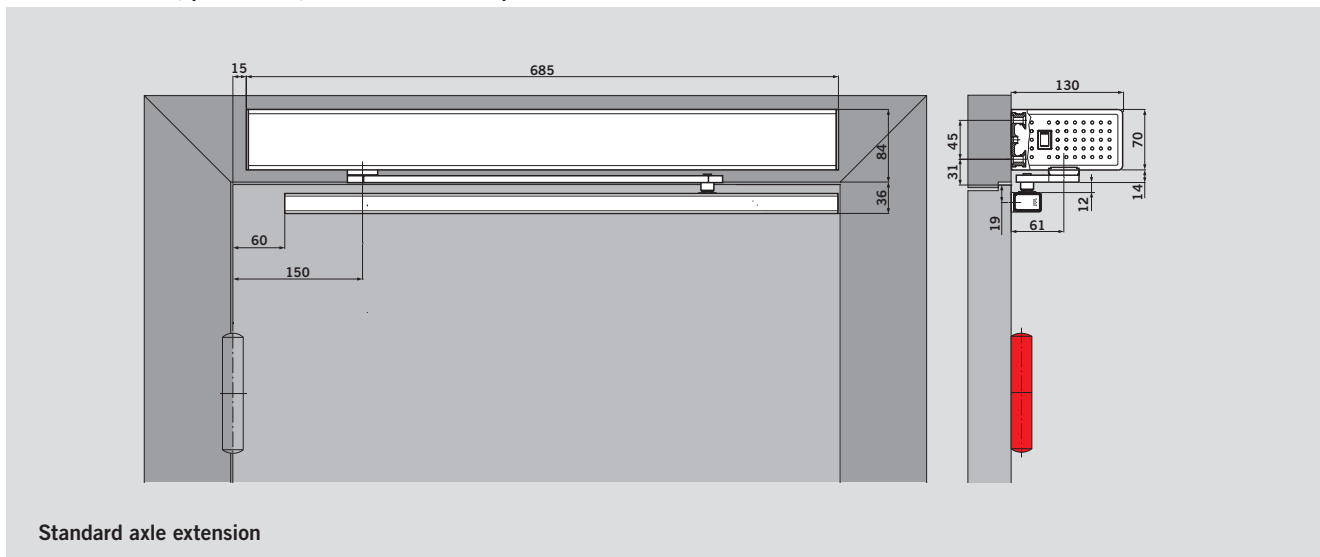

View: BASIC cover, push-version

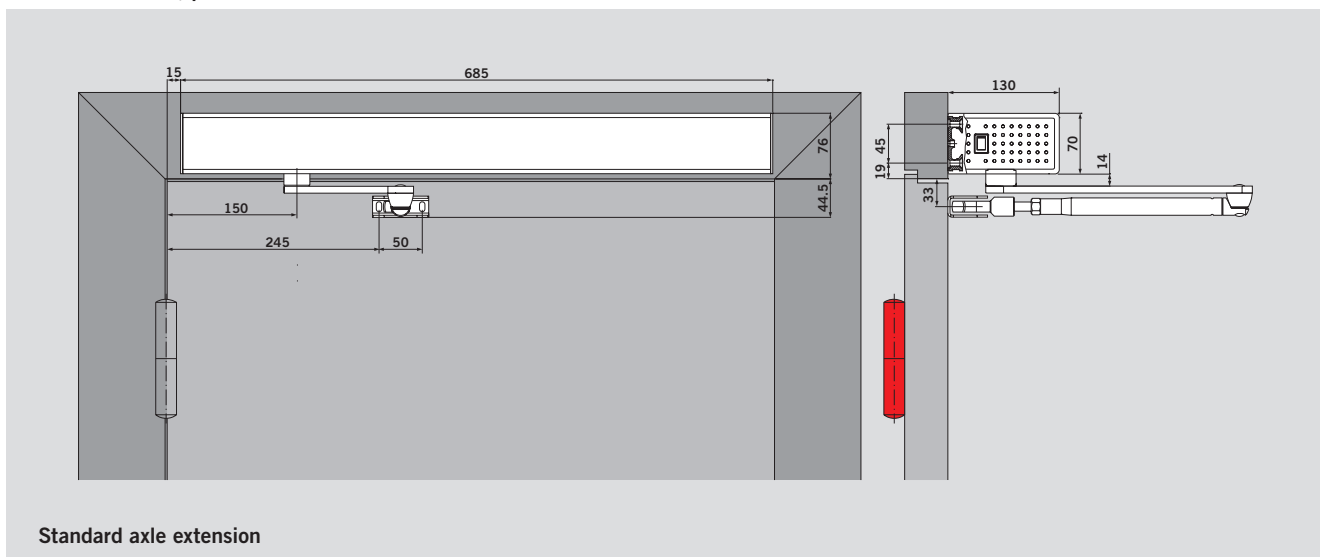

View: CONTINUOUS cover, pull-version, 12.5 mm drive arm pin

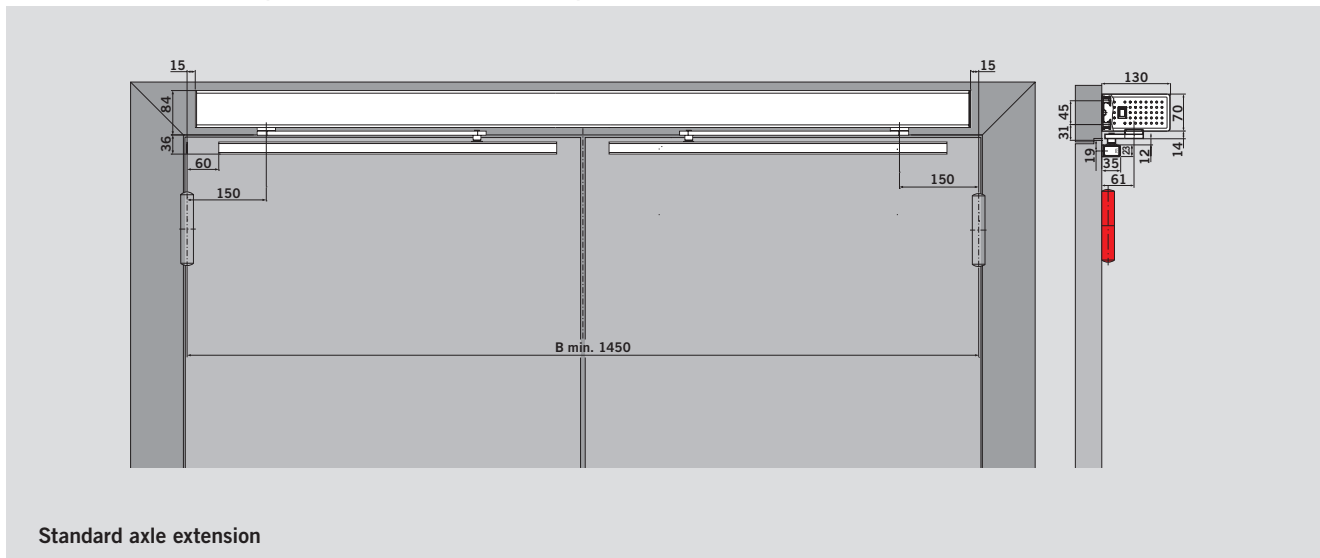

Drilling template: BASIC cover, pull-version, 12.5 mm drive arm pin

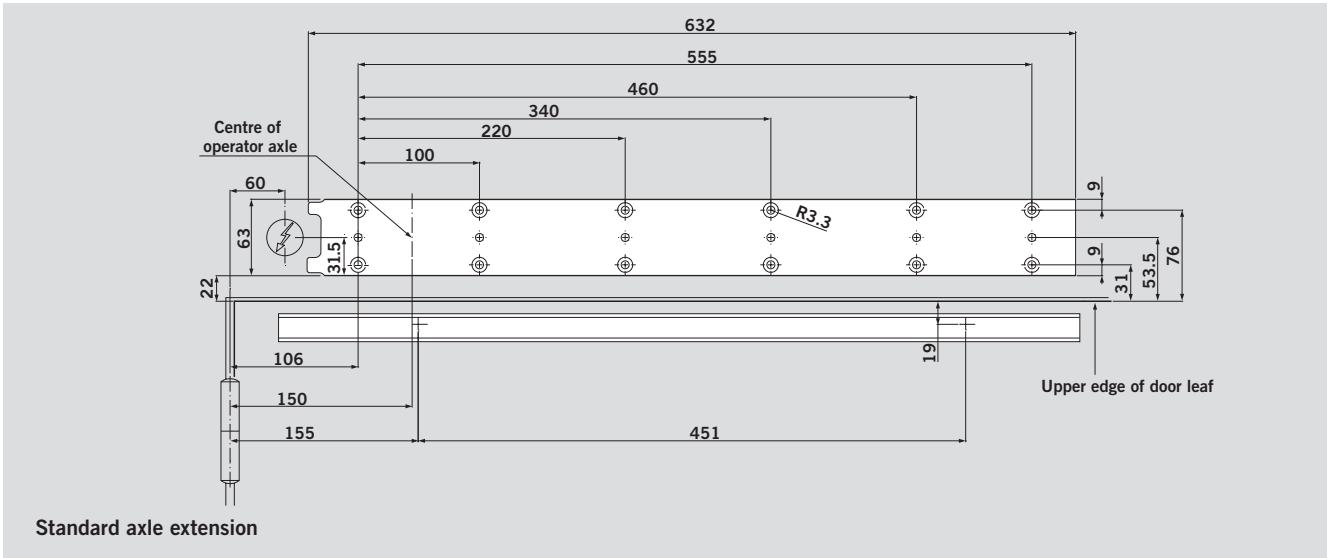

Drilling template: BASIC cover, push-version

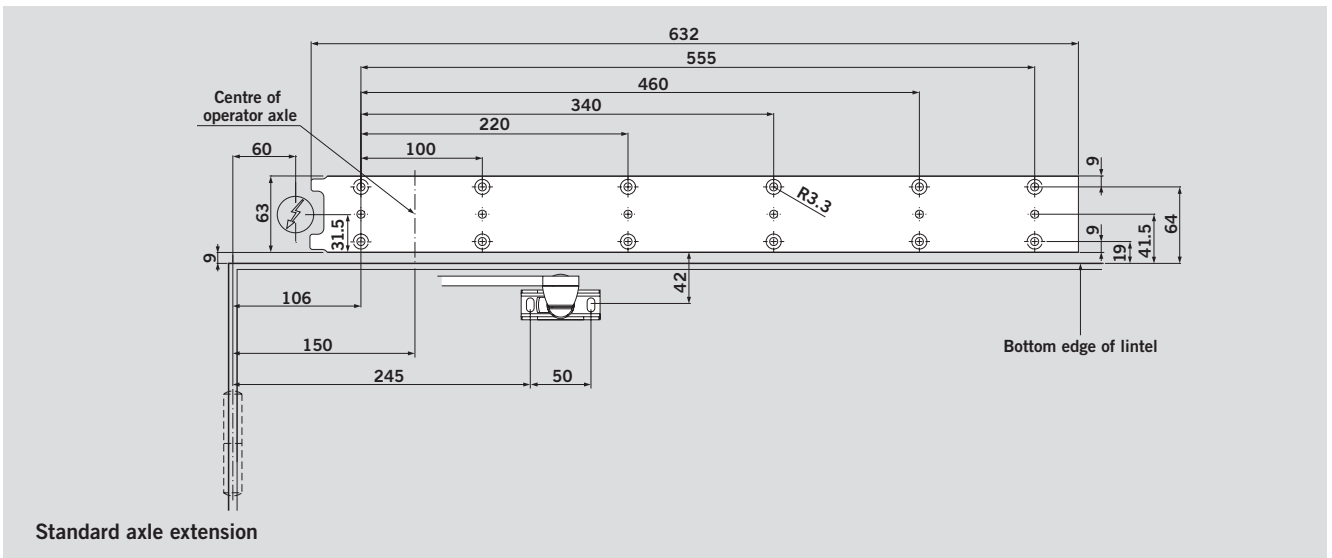

Drilling template: CONTINUOUS cover, pull-version, 12.5 mm drive arm pin

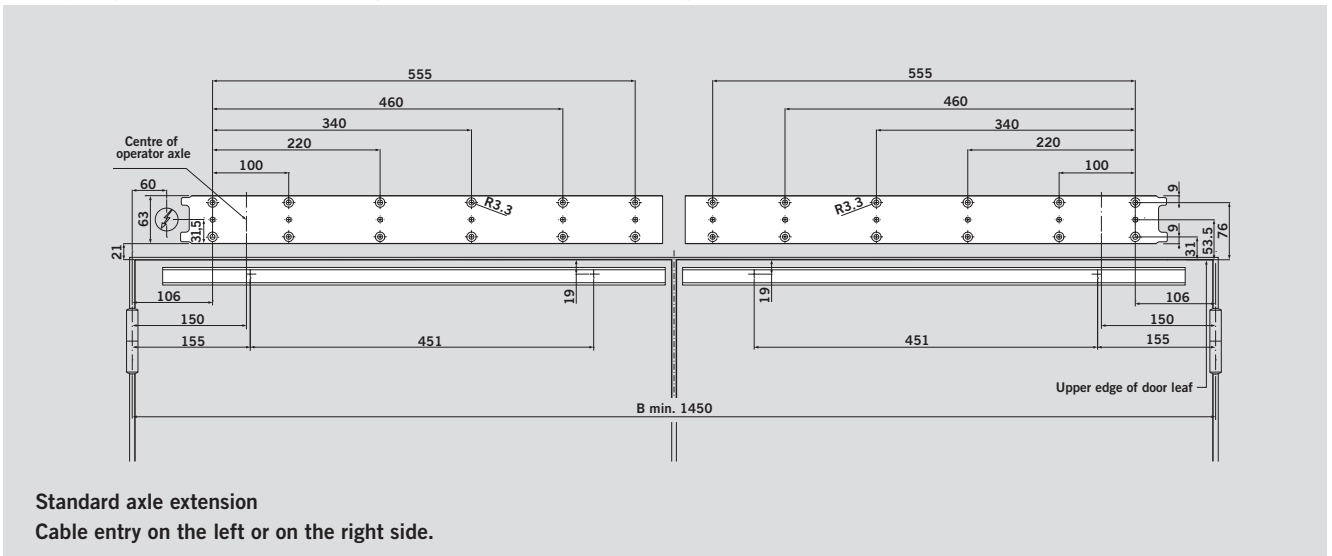

View: CONTINUOUS cover, push-version

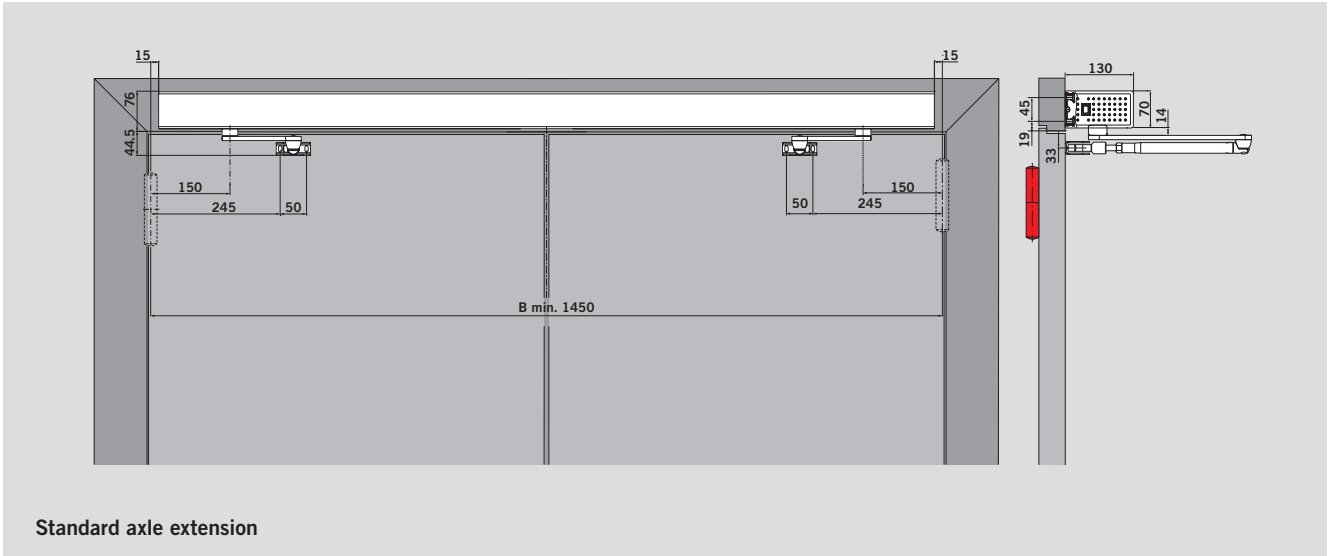

View: BASIC cover, pull-version, 25 mm drive arm pin, pivoted door

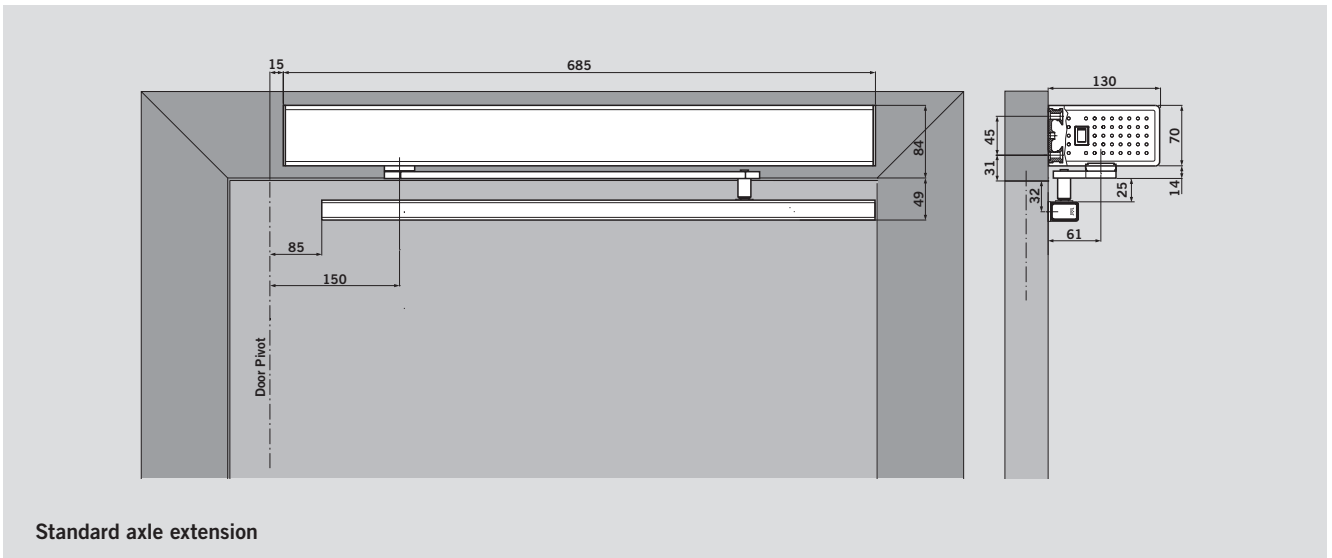

View: BASIC cover, push-version, pivoted door

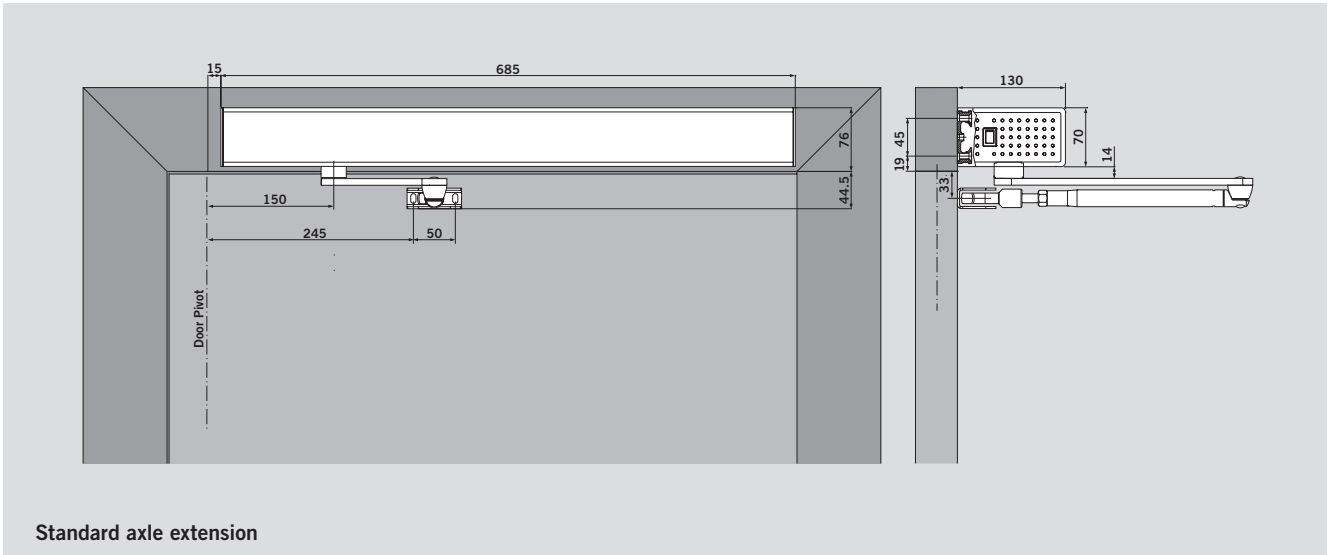

Drilling template: CONTINUOUS cover, push-version

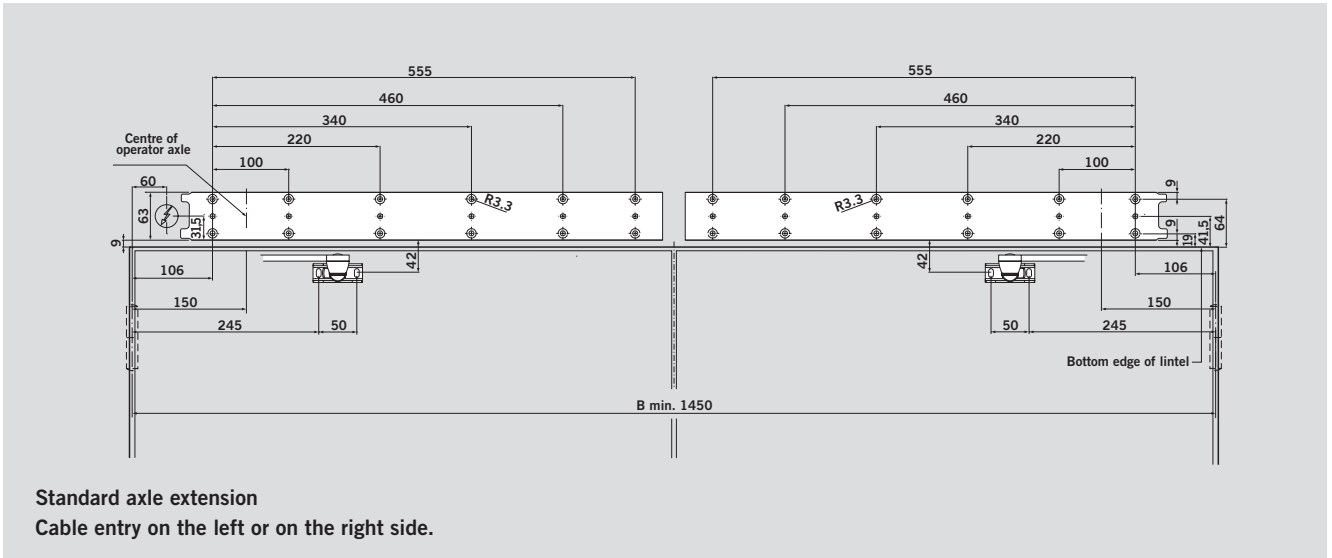

Drilling template: BASIC cover, pull-version, 25 mm drive arm pin, pivoted door

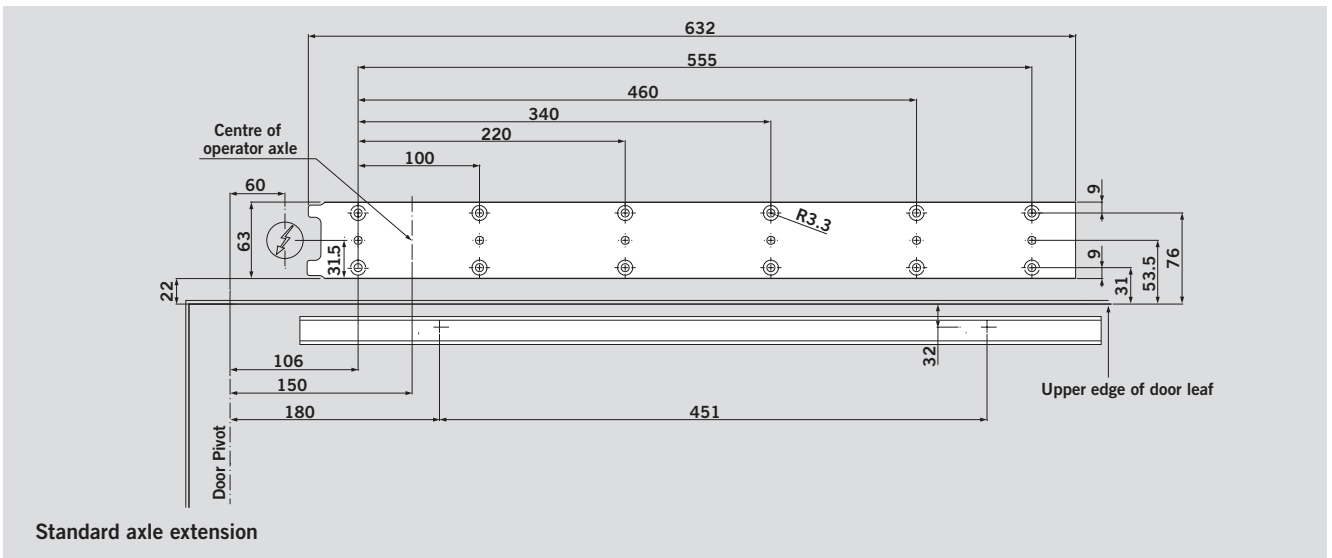

Drilling template: BASIC cover, push-version, pivoted door

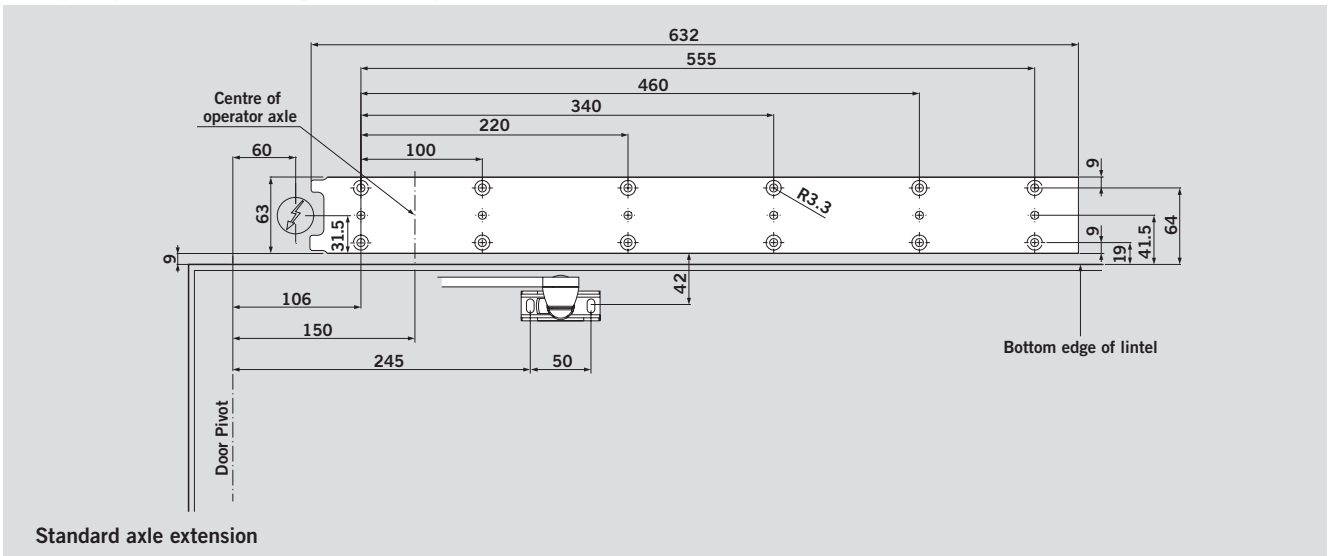

View: CONTINUOUS cover, pull-version, 12.5 mm drive arm pin, pivoted door

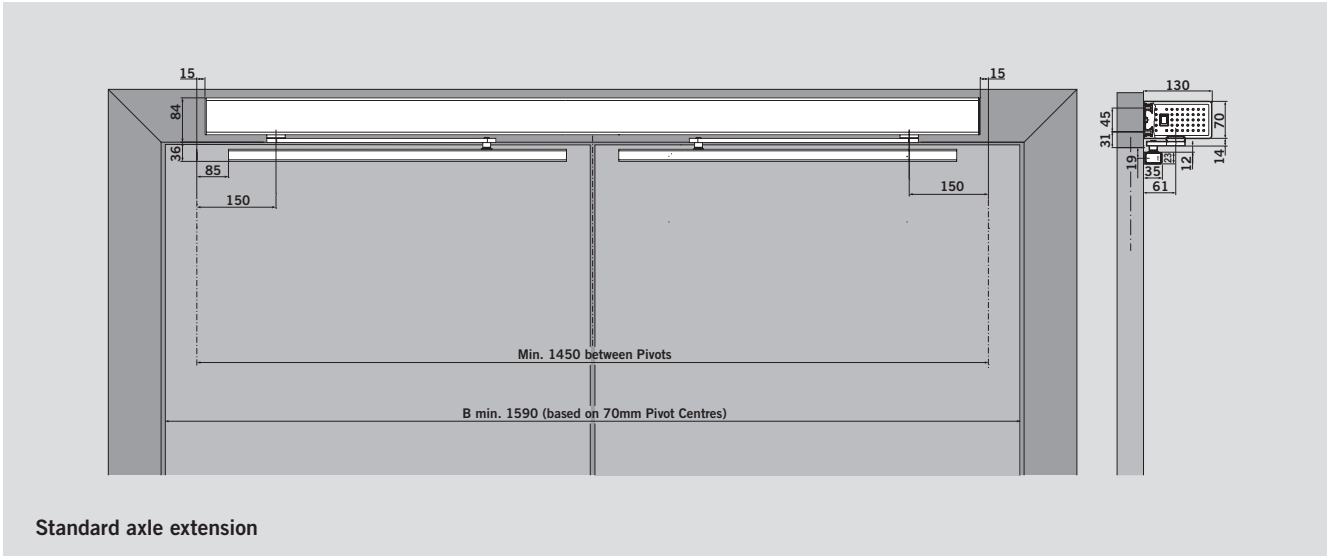

View: CONTINUOUS cover, push-version, pivoted door

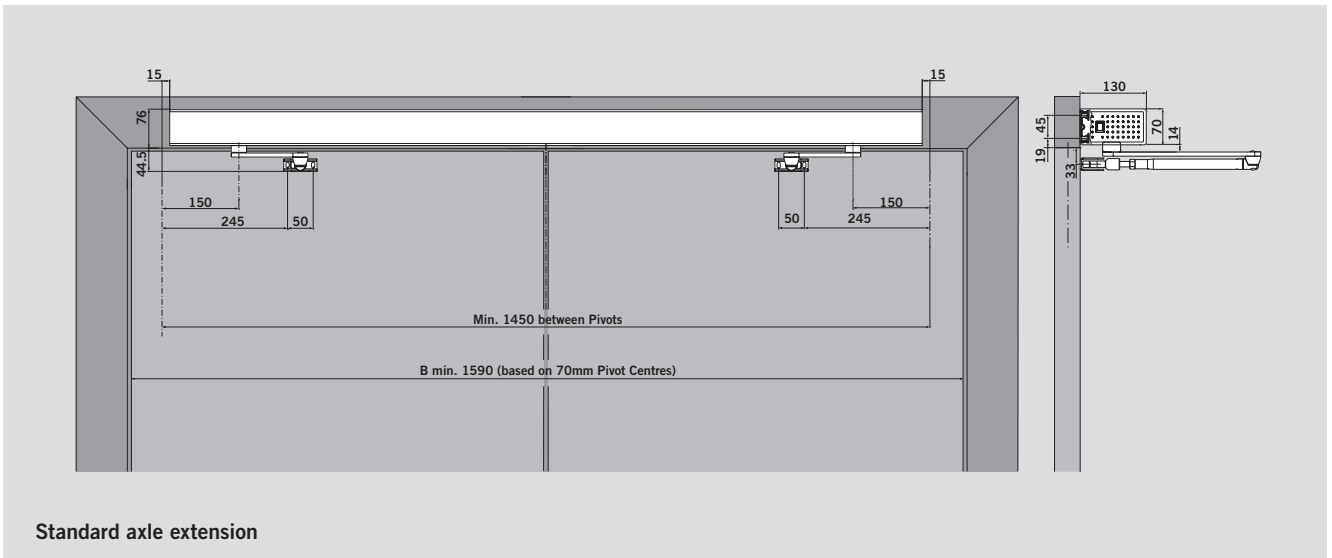



Drilling template: CONTINUOUS cover, pull-version, 12.5 mm drive arm pin, pivoted door

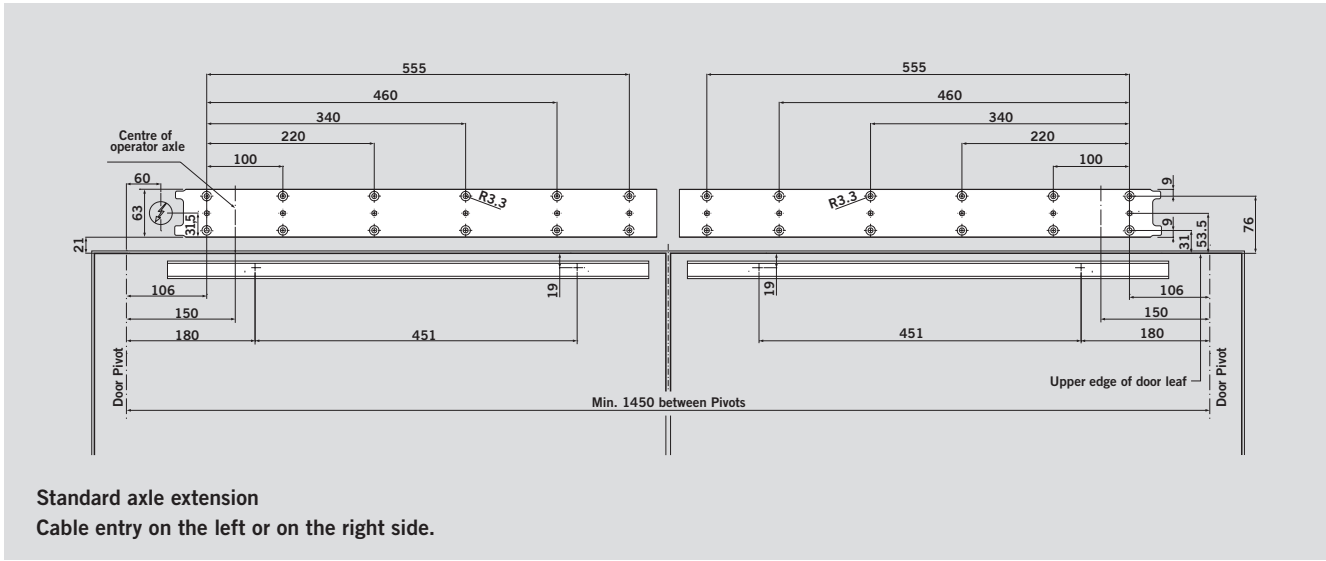

Drilling template: CONTINUOUS cover, push-version, pivoted door

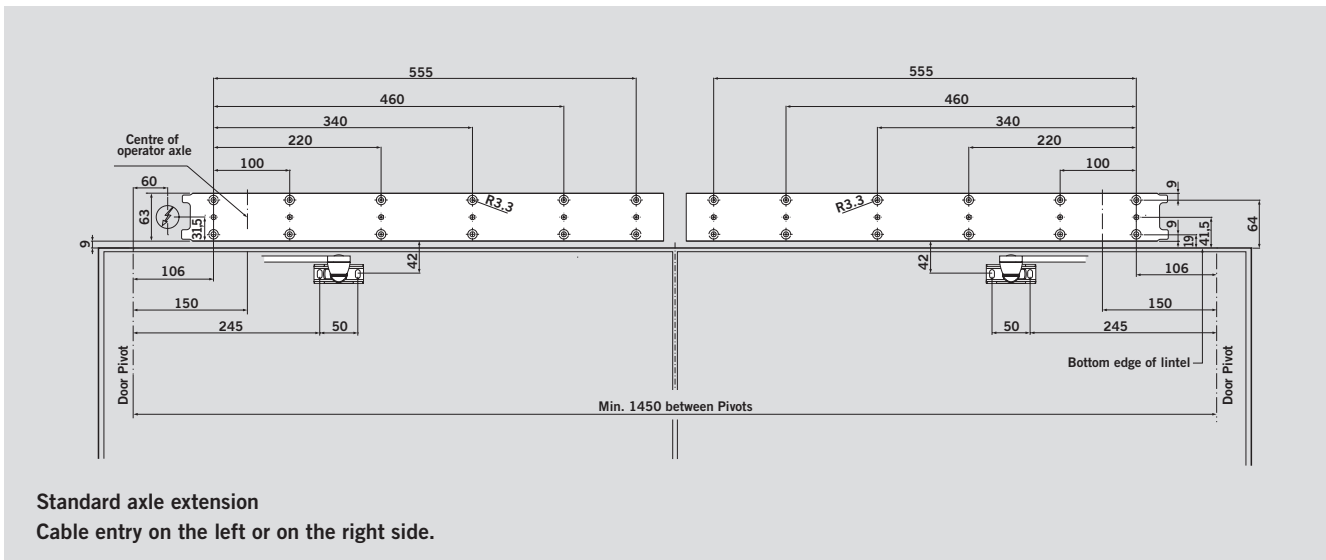

## SYSTEM SETUP

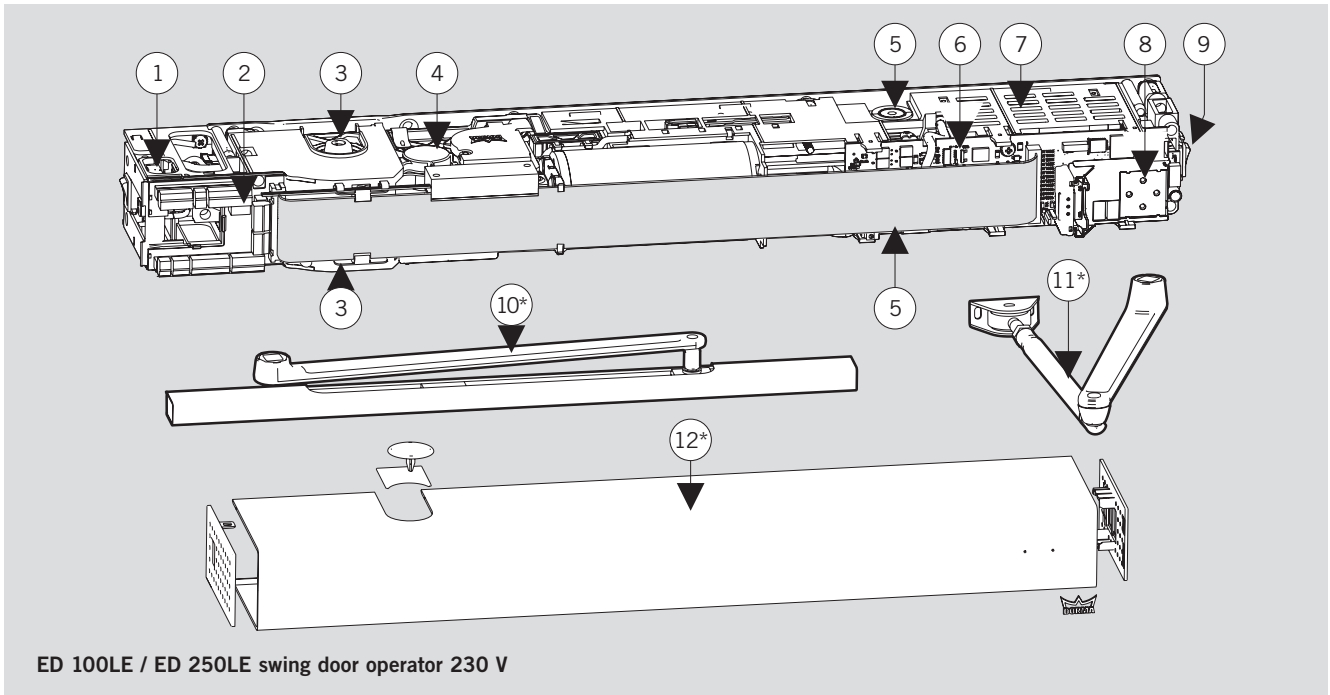

ED 100LE / ED 250LE swing door operator 230 V

The example system is equipped with all possible components. It is selected in accordance with the door-leaf width and the door-leaf weight.

- |                                 |                                    |   |                               |
|---------------------------------|------------------------------------|---|-------------------------------|
| 1 Mains connection              | 4 Drive system (motor/gear/spring) | 7 Switching power supply unit             | 10 Slide channel (Set)*       |
| 2 Connection unit               | 5 Adjustment of closing force      | 8 User interface with information display | 11 Standard arm*              |
| 3 Axle connection on both sides | 6 Control unit                     | 9 Internal program switch                 | 12 Complete cover (ED BASIC)* |
- \*supplied separately

## ARM

### ED slide channel set – pull-version

The slide channel set is suitable for doors with a door-leaf width of 1,600 mm. The maximum lintel depth amounts to +/- 30 mm. (Number 10 in above diagram)

### ED standard arm 225 – push-version

The standard arm is suitable for lintel depths of up to 225 mm, admissible door-leaf width of 1,600 mm. (Number 11 in above diagram)

For lintel depths from 0 to 225 mm

ED 100 arm 225 to 300 mm

ED 250 arm 225 to 500 mm

## COVERS

DORMA provides covers for single and double-leaf systems. All covers feature the DORMA Contur design and are designed for on-site mounting.

### ED BASIC cover

Aluminium cover for single-leaf swing door systems.

### ED VARIO cover

This cover combines with the ED BASIC cover to provide a continuous cover for double leaf swing door systems. In addition to the VARIO cover you will require two ED BASIC covers which are mounted on the left and the right of the operator system.

### ED PROFESSIONAL cover

Designed for double-leaf swing door systems, the ED PROFESSIONAL cover is a continuous and seamless cover available in lengths from 1400 mm to 3,200 mm. Also, single-leaf operators may be extended to a length of up to 3,000 mm towards the main closing edge.

### ED BASIC and VARIO covers

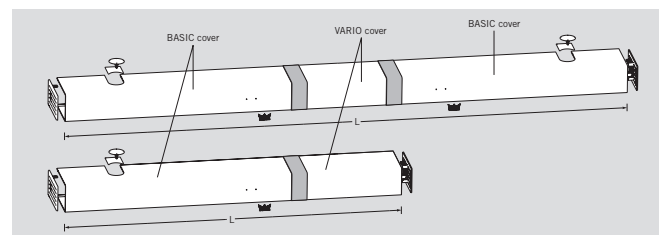

### ED PROFESSIONAL cover

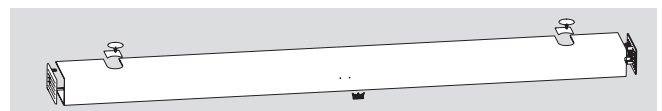

ED 100LE / ED 250LE, single-leaf doors

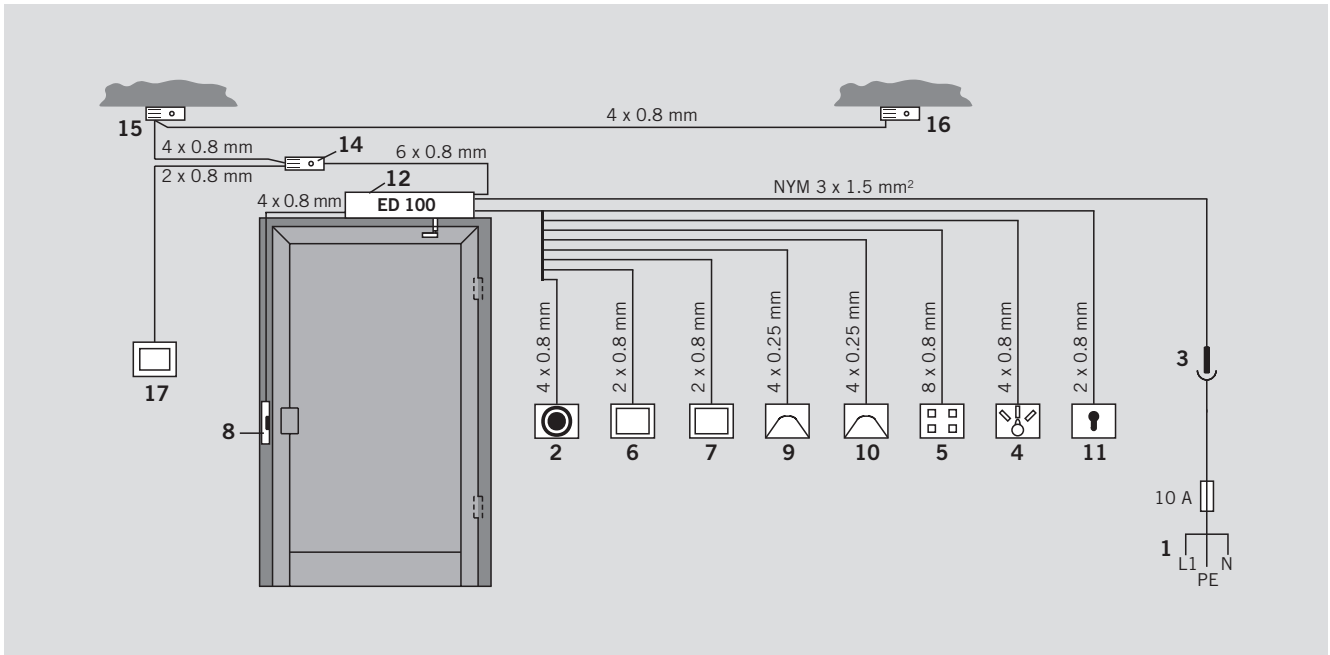

ED 100LE / ED 250LE, double-leaf doors

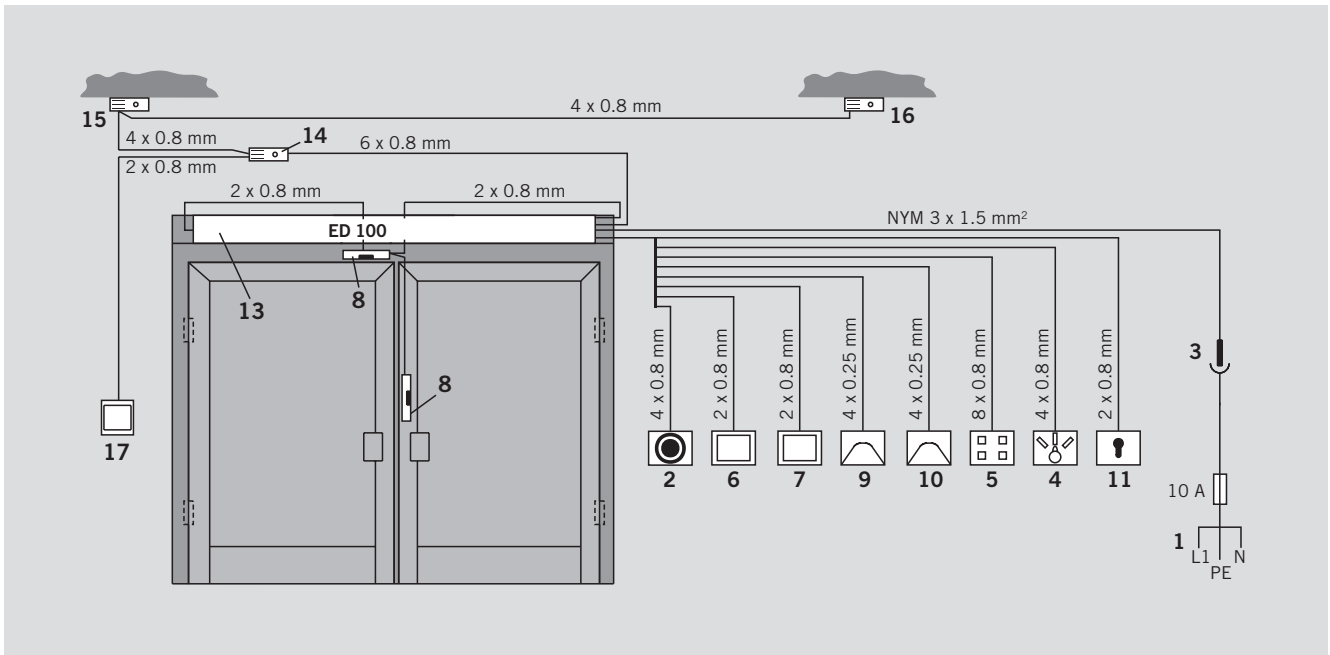

Connections

- |   |                                  |  |                                       |
|---|----------------------------------|--|---------------------------------------|
| 1 Power supply                                  | 6 Pushbutton, inside             | 12 ED 100LE / ED 250LE                       | 16 RM-N smoke detector, hinge side    |
| 2 Emergency pushbutton, function: Emergency Off | 7 Pushbutton, outside            | 13 ED 100LE / ED 250LE with continuous cover | 17 Optional manual release pushbutton |
| 3 Two-pole-and-earth socket                     | 8 Locking device                 | 14 RM-ED smoke detector                      |                                       |
| 4 External PGS, mechanical                      | 9 Radar motion detector, inside* | 15 RM-N smoke detector, opposite hinge side  |                                       |
| 5 External PGS, electronic                      | 10 Remote actuation              |  | * Not sold for LE operator            |
|   | 11 Key switch                    |  |                                       |

## OPTIONS - PROGRAM SWITCHES

### PG-D3

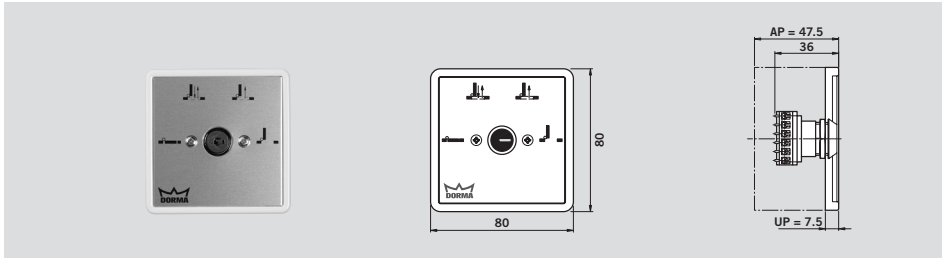

#### Program switch PG-D3

4-position, lockable, aluminium, white, flush-mounted version, Gira S-Color

### EPS-D

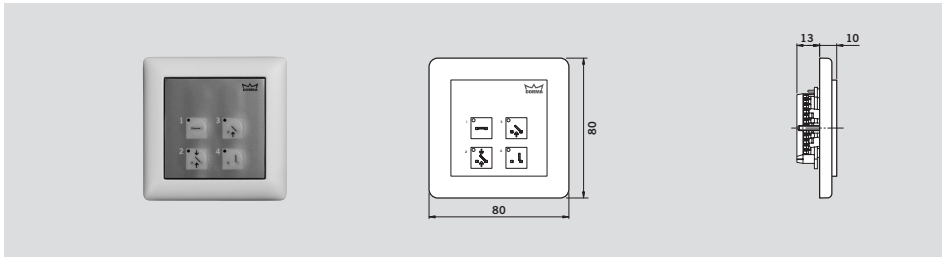

#### EPS-D full-electronic program switch

In System 55 design, 4-position, lockable via code or additional TL-ST S55 key switch, membrane keypad, aluminium-coloured, white, flush-mounted version

### ESR – Integrated door coordinator

The ESR set is installed inside the double-leaf operator on site. It is available as an individual component and is easy to

install. The system works similar to a drum brake and thereby ensures the proper functioning of the system. The brake is

released when the passing leaf is fully closed allowing the active leaf to close in turn.

## OPTIONS - RADAR MOTION DETECTOR

### Easy Motion radar motion detector with direction recognition



Radar motion detectors respond to movements. They detect approaching people within their detection range and trigger the activation (opening) signal at the door operator. Adjustable to allow for difficult installations.

#### Easy Motion

With direction recognition, black  
black rain cover\*

\*DORMA recommends installing a rain cover for outdoor applications.

## OPTIONS - SAFETY BARRIERS

### Framed 'F' type safety barriers

BS EN 16005:2012 Power operated doorsets – Safety in use states: Barriers are intended to direct pedestrian traffic or to avoid pedestrians from entering non-safe zones. They shall be a) designed so that children cannot easily climb over or crawl under them, b) suitably secured, c) able to withstand forces occurring in normal service, d) a minimum of 900 mm high. Barriers, when used, shall not create new hazards.

DORMA offer the following range of barriers to ensure compliance.



#### Framed 'F' type with glass infill.

Silver painted aluminium frame. 10mm toughened glass infill.

#### Framed 'F' type with solid infill.

Silver painted aluminium frame. Silver painted aluminium sheet infill

## OPTIONS - BACK EDGE PROTECTION

### Pivotsafe and Hingesafe

BS EN 16005:2012 Power operated doorsets – Safety in use states: Danger points between the leaf and frame presenting a fingertrap hazard shall be avoided structurally or by an appropriate protective device or safeguards provided by means of protective measures.

To ensure that installations carried out by DORMA meet the strictest safety standards we offer a range of options suitable for the majority of door types.

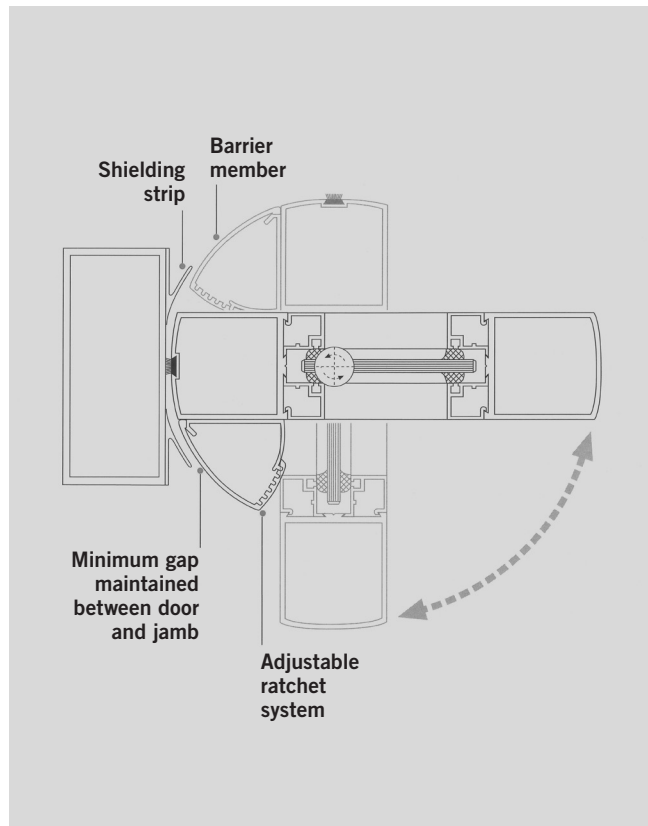

#### Pivotsafe for pivoted doors.

Aluminium. Available in anodised or RAL painted finishes. Suitable for conventional doors with pivot centres between 50mm and 75mm

#### Hingesafe for hinged doors.

UVPC. Available in either white or brown.



# INFARED SAFETY SENSORS

**Safety**



**Reversing**



**Stop**



DORMA infrared safety sensors are active infrared sensors and designed to detect all static and moving obstructions, either people or objects, within their detection range. On the opposite hinge side, the

infrared safety sensor fulfils the function of an activator, which means that the sensor will institute the door to reverse and open as soon as an obstruction is detected in the course of a closing cycle. Then the hold-

open time starts anew. On the hinge side, the infrared safety sensor will interrupt the automatic movement of the door whenever it detects an obstruction; the door closes on expiry of the adjusted hold-open

time. DORMA infrared safety sensors are available in different lengths and may be supplied in the same colour as the operator.

## IRS-4 active infrared safety sensor

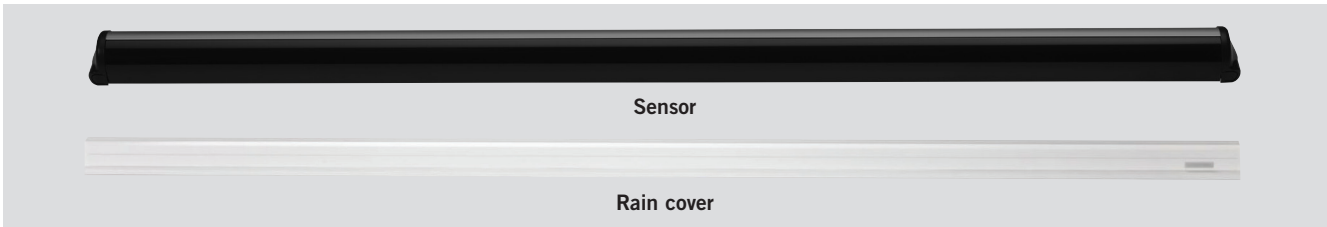

IRS-4 active infrared safety sensor c/w cable & loop	Colour	Part number
IRS-4 With one sensor, length: 350 mm	silver	294350
IRS-4 With two sensors, length: 1100 mm	silver	294110

IRS-4 weather protection hood	Part number
IRS-4 Length: 350 mm	294352
IRS-4 Length: 1100 mm	294112

## ESM Energy Saving Mode

The Energy Saving Mode is available when the IRS-4 is installed in combination with the ED 100LE / ED 250LE swing door operator.

The sensors automatically switch to Stand-By Mode as soon as the program switch at the operator is adjusted to OFF.





DORMA UK Limited  
Wilbury Way  
Hitchin  
Hertfordshire  
SG4 0AB

Tel: 01462 477600  
Fax: 01462 477601  
E-mail: [autos@dorma-uk.co.uk](mailto:autos@dorma-uk.co.uk)

DORMA Ireland Limited  
PO Box 1050  
Maynooth  
Co. Kildare

Tel: 01 295 8280  
Fax: 01 295 8284  
E-mail: [info@dorma.ie](mailto:info@dorma.ie)

[www.dorma.com](http://www.dorma.com)